

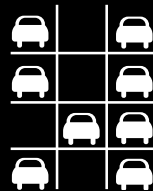

**Integrated Parking Solutions**  
For High-Density Communities

DATA SHEET:

**Chain Puzzle System**



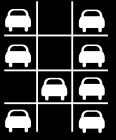

# Chain Puzzle System

SilMan Automated Parking Systems (SAPS) is a leading provider of mechanical parking solutions, helping architects and developers maximize occupancy and build sustainable communities. This document provides an overview of our Chain Puzzle System, a cost-effective, pre-engineered modular approach to optimize space within residential and commercial structures.

All SAPS systems meet ASME B 20.1 v2024 and NFPA 79 v2024 standards.

## System Overview

The Chain Puzzle is our most popular offering. The system mechanically transports vehicles vertically and horizontally for storage and retrieval and may be implemented single or tandem-deep. It is ideally suited for high-density developments challenged by limited space for parking.

The Chain Puzzle System provides up to 4 levels of vertical capacity, including the option for one level below ground (-1/+3).

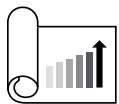
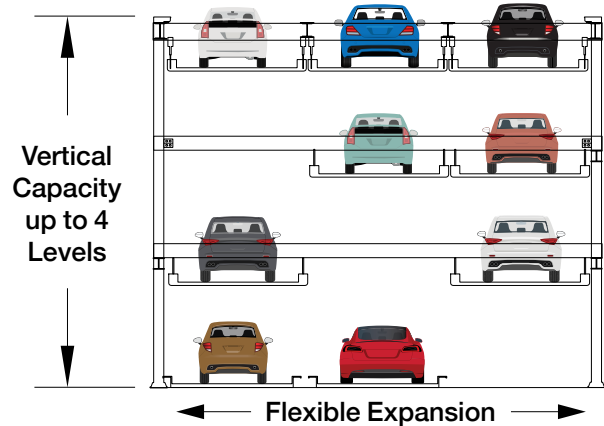

Watch for **Enhanced Performance** alerts throughout this document for ways to optimize your system operations and user experience.

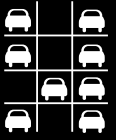

# Chain Puzzle System

## Chain Puzzle Operation

As the name implies, the Chain Puzzle System raises and lowers vehicle platforms by a chain driven mechanism. All levels, other than the top, reserve one platform position to facilitate vertical motion. Pallets on these levels move transversely to create vertical channels, allowing vehicles to move up and down, to and from ground level. Spaces on the top (and single-level pit, if included in the design) may be fully occupied, maximizing space utilization. Users store and retrieve vehicles from the ground level, where the system is alerted to their intent by a fob or touchscreen kiosk interface. An attendant is not required.

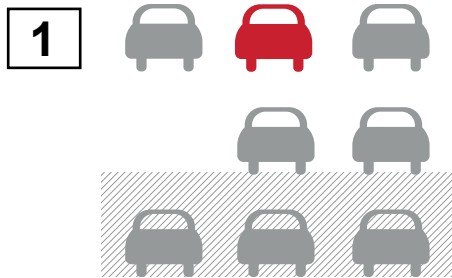

Vehicle called

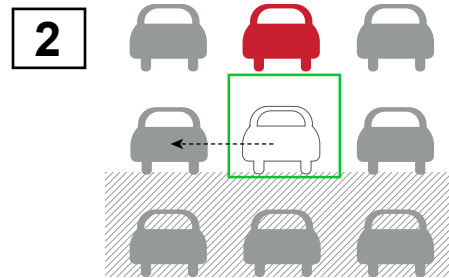

Pallets shift to clear path for exiting vehicle

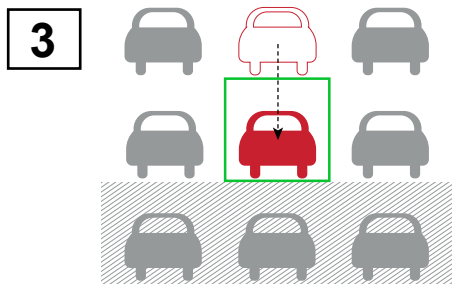

Vehicle moves to grade level

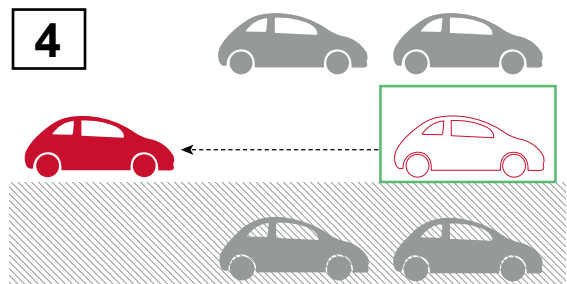

Vehicle exits system

[View an animation of the Puzzle System](#)

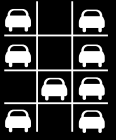

# Chain Puzzle System

## System Details

**Below Grade  
Space Around System  
Center Line  
Outside  
Clearances**

## Dimensions

Detailed dimensions and clearances are crucial for the successful installation of the Chain Puzzle System. This section provides information on the space requirements for below-grade installations, center line dimensions, outside dimensions, and necessary clearances to ensure seamless integration with your building structure.

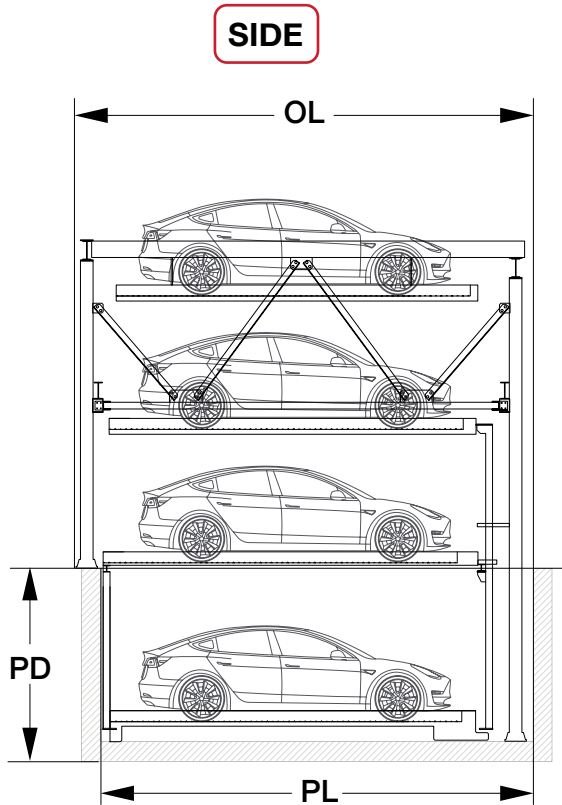

	Area	Dimension
<b>OL</b>	Overall Length	21' - 4"
<b>PL</b>	Pit Length	19' - 7"
<b>PD</b>	Pit Depth	8' - 1"

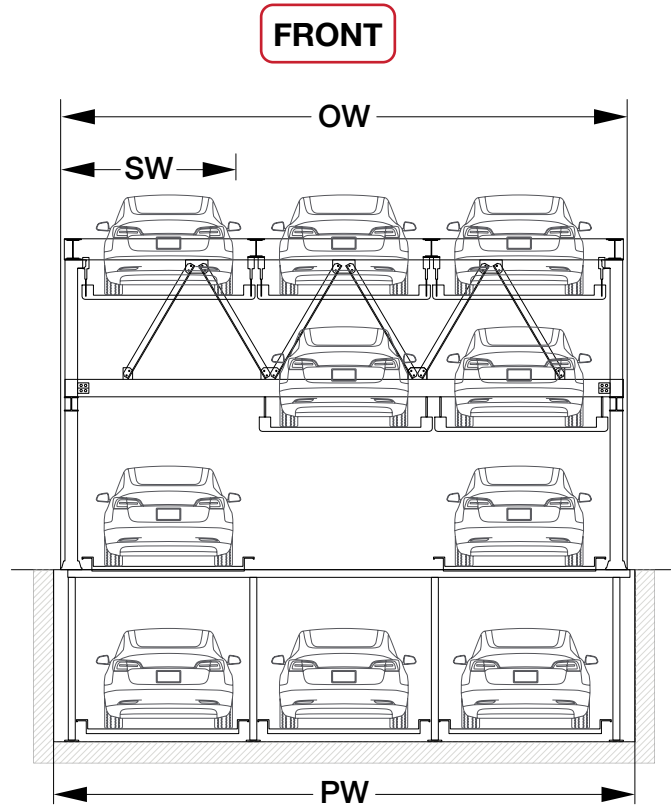

	Area	Dimension
<b>OW</b>	Overall Width	27'
<b>PW</b>	Pit Width	26' - 12"
<b>SW</b>	Space Width	8' - 7"

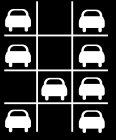

# Chain Puzzle System

## System Details

## Standard Capacity

### Vehicle Dimensions Pallet Sizes

The Chain Puzzle System is designed to accommodate a wide range of vehicle sizes and weights. This section addresses the standard vehicle dimensions that the system can handle, along with the corresponding pallet sizes and weight capacities.

	Dimension	Standard
	Vehicle Weight (lbs)	5,200
<b>Wm</b>	Vehicle Width - Mirror-to-Mirror (ft-in)	8' - 6"
<b>Wv</b>	Vehicle Width - Wheel-to-Wheel (ft-in)	6' - 10 3/4"
<b>Wp</b>	Pallet Width (ft-in)	8' - 6"
<b>Lv</b>	Vehicle Length (ft-in)	17' - 1"
<b>Hv</b>	Max. Height (ft-in)	7' - 0"
<b>Lp</b>	Pallet Length (ft-in)	18' - 1 1/2"

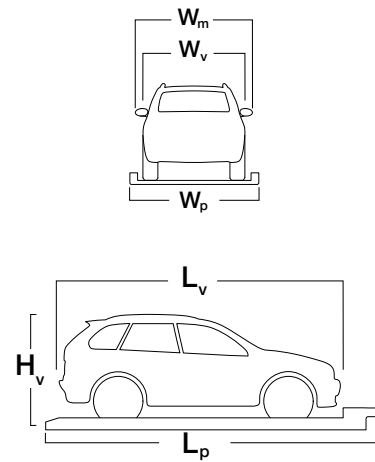

### Upgrades

- Vehicle capacity to 6,000 lbs
- Vehicle height from 5' - 0" to 7' - 0"
- Custom pallet sizes

For additional Options, refer to page 9.

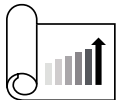

**Enhanced Performance:** Our in-house design team consults directly with you to optimize vehicle size and weight parameters for your project.

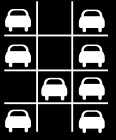

# Chain Puzzle System

## System Details

### Space Needed To Access System

## Approach/Exit

This section details the area needed for entry and exit to and from the system. For reference, here are sample turning radii for various vehicles.

Vehicle Make	Vehicle Model	Turning Radius
Chevrolet	Malibu	18' - 6"
Tesla	Model Y	19' - 10"
Nissan	Altima	18' - 8"

## System Finish

### Finish Options

## Standard Specifications

The choice of finish depends on the environmental conditions of the installation site. A powder coat is suitable for most environments, while galvanized steel is recommended for areas with harsh weather conditions.

### Powder Coat

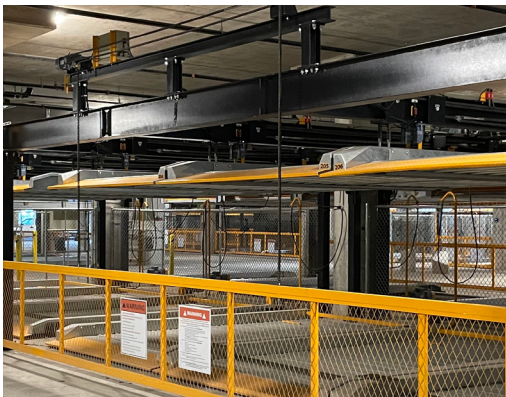

### Galvanized



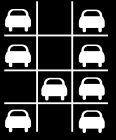

# Chain Puzzle System

## Electrical Specifications

### Standard Specifications

The control system manages the operation of your Chain Puzzle System. Devices include motors, sensors, controllers, and other components that detect the location of vehicles and manage their movements. Users control the system with key fobs and via kiosk screens.



Standard electrical specification is:

- 480 or 208VAC 3-Phase with Neutral
- Ampacity based on voltage and system configuration

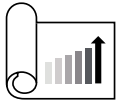

**Enhanced Performance:** Your user controls interface can be expanded to create a network of kiosk screens for convenient operation. A customized remote interface can also be created for property managers and owners to monitor and administer the parking system. Remote monitoring for quality service and performance is available with the SAPS full-service and support program.

## Fob and Touchscreen Kiosk

The Chain Puzzle System is user-friendly, allowing drivers to alert the system of their intent to store or retrieve their vehicles using a fob or touchscreen kiosk.

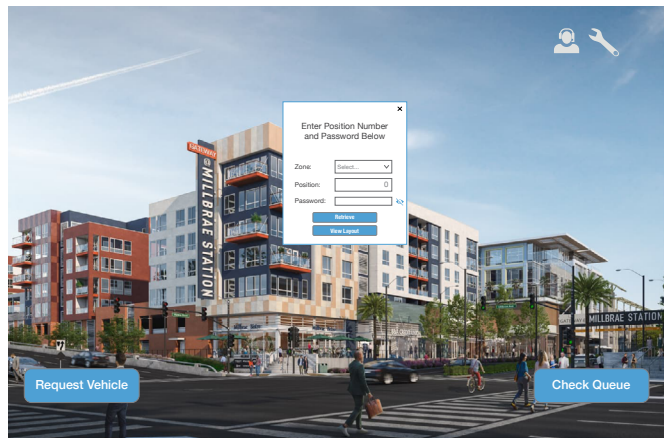

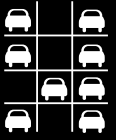

# Chain Puzzle System

## Impact on Building Systems

### Construction

The Chain Puzzle System can be designed as a self-supporting structure, requiring minimal attachment to the building slab. This approach allows for easy integration with existing systems and minimizes disruptions during installation. Additionally, the system's versatility enables seamless incorporation into a wide range of building types.



## Noise Monitoring and Testing

During operation, the system is intermittently 25 dBA above the ambient garage noise level and is estimated to be 80 – 90 dBA, depending on the surrounding acoustics.

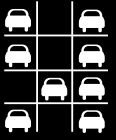

# Chain Puzzle System

## Slab, Embedment, and Drain Slope Requirements

### Slab

The system requires a minimum 6-inch (152 mm) thick slab with a compressive strength of 3,000 psi (20.7 MPa) to support the weight and operation of the parking system.

### Embedment

Embedment is not required for the installation of the parking system, simplifying the construction process and minimizing disruption to the existing structure.

### Drain Slope

A drain slope of 2% (1/8 inch per foot) is recommended for proper drainage and to prevent water accumulation within the parking system. Collaboration with the Architect is essential to confirm that the drainage system is compatible with the parking system design and functions effectively.

## Options

### Chain Puzzle System Options

- Remote monitoring and support
- Centralized kiosk
- EV charging
- Life-cycle support services

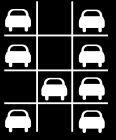

# Chain Puzzle System

## Appendix

### Warranty

SilMan Automated Parking Systems offers a standard one-year warranty on all mechanical parking systems. This warranty includes a one-year service contract with quarterly onsite inspections to ensure optimal system performance and address any potential issues.

### Maintenance, Service, and Support

SilMan is committed to providing comprehensive maintenance, service, and support for all of our automated parking systems. We offer a range of service plans to meet your specific needs, ensuring that your system operates smoothly and efficiently throughout its lifespan.

### Retrieval Times

Retrieval times are an essential criteria for architects and developers when selecting a high-density parking system. When comparing retrieval times between mechanical parking and surface systems, it is crucial to consider the time spent walking and driving in a surface or ramp parking lot to make an accurate comparison.

Parameters affecting retrieval times:

- Size of system
- Distance of the vehicle from the pick-up location
- Number of users at a given time
- Retrieval activation method
- Number of entries and exits
- Advance queue via remote touchscreen kiosk or mobile app

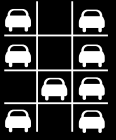

# Chain Puzzle System

## User Safety

Gates and screens restrict access to the system while in use. Testing the safe operation of gates occurs during the commissioning process. Mechanical parking systems also contain uneven walkways and low head clearance, requiring the installation of safety signage before public use of the parking system.

Safety signage, lighting, etc. are outside the parking scope and is installed by others.

## Items Beyond Parking System Scope

### ADA Requirements

The Chain Puzzle System is not ADA compliant.

### Fire Suppression and Safety

Fire control systems, safety signage, and lighting are not included in the Chain Puzzle System and should be installed by qualified professionals to guarantee compliance with safety regulations.

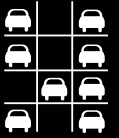

## Mechanical Parking is Building Value

The SAPS Chain Puzzle is a remarkably straightforward solution, applicable in a wide variety of situations for improved efficiency and revenue opportunities.

Moreover, SilMan's "One Team" approach delivers unique value as a mechanical parking system provider, offering self-performed services throughout every phase of your project.

---

SilMan Industries is a well-established automation and industrial service provider. Since 2015, the company has installed over 4,000 automated parking spaces in communities just like yours.

---

### Contact a

SAPS  
Parking  
Professional

**p.** 510.347.4800

**f.** 510.347.4801

parking@silmanindustries.com  
silmanautomatedparkingsystems.com

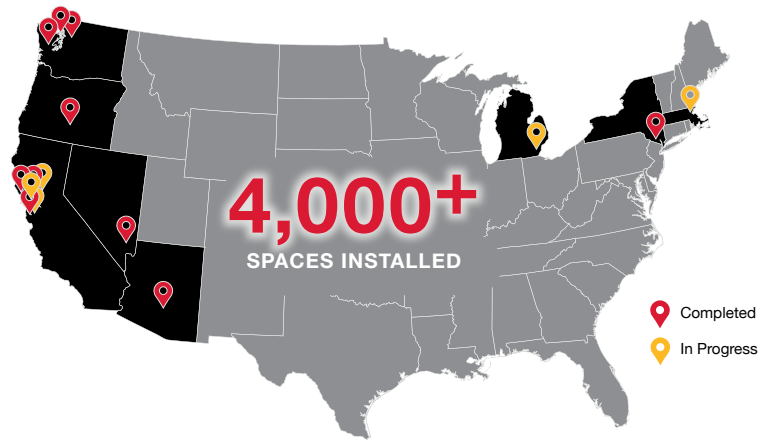

SilMan Automated Parking Systems  
is a division of SilMan Industries